



Toll Free: 1-800-579-8088 Web: www.zinko.com

MODEL

# ZHP-20 & ZHP-41

## Single-Speed Hydraulic Hand Pumps

### Operation & Maintenance Manual

#### Important Receiving Instructions

Visually inspect all components for shipping damage. Shipping damage is NOT covered by warranty. If shipping damage is found, notify carrier at once. The carrier is responsible for all repairs and replacement costs during product shipping.

#### Safety Information

Read and follow all instructions, warnings, cautions and carefully. Follow all safety precautions to avoid personal injury or property damage during system operation. ZINKO is not responsible for damage or injury resulting from unsafe product use, lack of maintenance, or incorrect product and/or system operation. Contact ZINKO when in doubt as to the safety precautions and operations. Failure to comply with the following cautions and warnings could cause equipment damage and personal injury.

#### Caution Remarks Used In This Manual

**WARNING** indicates a potential danger that requires correct procedures or practices to avoid personal injury.

**CAUTION** is used to indicate correct operating maintenance procedures and practices to prevent damage to or destruction of equipment or other property.

#### Operator Responsibility

It is the operator's responsibility to read and understand all of the following safety statements:

**WARNING**

1. Make sure that all system components are protected from external sources of damage, such as excessive heat, flame, moving machine parts, sharp edges, and corrosive chemicals.
2. **WEAR PROPER PERSONAL PROTECTIVE GEAR WHEN OPERATING HYDRAULIC EQUIPMENT.**
3. Always check product limitations regarding pressure ratings, load capacities, and setup requirements. The system operating pressure **MUST NOT** exceed the pressure rating of the lowest rated component in the system.
4. **NEVER** set the relief valve to a higher pressure than the maximum rated pressure of the pump. Higher settings may result in equipment damage and/or personal injury.

#### Installation

##### Connecting the Pump

1. Thread hose into pump outlet. Use 1-1/2 wraps of Teflon tape (or suitable thread sealant) on hose fitting, leaving the first complete thread free of tape to ensure that tape does not shed into the hydraulic system causing damage. Trim loose ends.
2. Install a pressure gauge in-line from the pump for added safety and better control.
3. Connect the hose(s) to your cylinder or tool.

NOTE: **For single-acting cylinders:** Connect one hose from the pump to the cylinder.

**For double-acting cylinders:** Connect two hoses. Connect one from the pressure port of the pump to the pressure port of the cylinder. Connect another hose from the retract port of the pump to the retract port of the cylinder.

##### Pump Venting

Vented pumps provide slightly better performance. For pumps with a nylon reservoir, turn vent/fill cap 1/4 turn counter-clockwise to vent. Close vent prior to transporting pump to prevent oil leakage.

NOTE: When operating the pump in the vertical position, the hose end must be pointed down or the pump will pick up air and will not build pressure properly.

#### Operation

##### Before Using the Pump

1. Check all system fittings and connections to make sure they are tight and leak-free.
2. Check oil level in reservoir before operating pump. See *Maintenance* on page 2.

**WARNING** a) **Never add extensions to the pump handle.** Extensions cause unstable pump operation.  
b) In certain situations the pump handle can "kick back". Always keep your body to the side of the pump and away from the line of force.

NOTE: To reduce handle effort at high pressure, take short strokes. Maximum leverage is obtained in the last 5 degrees of the stroke.

# Zinko Hydraulic Jack

## Model: ZHP-20 & ZHP-41

### *Using Two-Speed Pumps*

These pumps provide two-stage flow. Under no load, the pump operates in the high flow stage for rapid advance. When the load is contracted, the pump automatically shifts to the second stage for building pressure. When pump pressure reaches approximately 200 psi, you must momentarily stop pumping and raise the handle to shift to the high pressure stage. After the pump shifts, pumping takes less effort.

NOTE: For best performance, operate handle at moderate speed during the high flow first stage. Rapid handle speed in the first stage will prevent the pump from delivering a full volume of oil.

### *Single-Acting Applications with Release Valve*

1. Close the release valve by turning clockwise.

**CAUTION** Close release valve finger tight **ONLY**. Using tools on release valve can damage it and cause the pump to malfunction.

2. Operate pump handle to deliver hydraulic power to the system. Pressure will be maintained until release valve is opened.
3. Open release valve (turn counterclockwise) to release pressure allowing oil to flow back to the reservoir.

### *Single-Acting Applications with 3-Way Position Manual Valve*

1. Shift valve handle to position 1.
2. Operate pump handle to deliver hydraulic power to the system. Pressure will be maintained until the valve is shifted.
3. To allow oil to return to the reservoir, shift valve handle to position 2.

### *Relief Valve Adjustment*

All pumps contain a factory set relief valve to prevent over pressurization of the system. Lower pressure settings can be obtained: contact your Authorized Service Center for more information.

### **Bleeding Air From the System**

#### *Air Removal*

Removing air from the hydraulic system will help the cylinder to advance and retract smoothly. Air can accumulate in the hydraulic system during the initial setup, or after prolonged use, which causes the cylinder to respond slowly or in an unstable manner.

#### *To Remove Air*

1. Position the cylinder at a lower level than the pump and turn the cylinder rod down.
2. With no load on the system and the pump vented, extend and retract the cylinder several times. Air will be released into the pump reservoir. Follow the fluid level instructions for your reservoir type to release the air from the reservoir and top off the fluid supply.

### **Maintenance**

Use only **ZINKO** hydraulic oil with these pumps to promote long pump life and protect your warranty. **ZINKO** seal kits are available for some hand pumps. Contact your **ZINKO** representative for more information on these products and/or other products.

#### *Adding Oil to the Pump*

**WARNING** Check oil level regularly. Always add oil with cylinders fully retracted (extended if pull cylinders) or the system will contain more oil than the reservoir can hold.

1. Remove vent/fill cap from reservoir.
2. Fill reservoir only to level mark shown on pump.
3. Remove air from system if necessary. Recheck oil level after removing air.
4. Return vent/fill cap to proper position.

NOTE: Non-vented hand pumps require air completely filled or a vacuum will form preventing oil from flowing out of the pump.

#### *Keeping Oil Lines Clean*

When coupler halves are disconnected, always screw on dust caps. Use every precaution to guard unit from dirt entering the system because foreign matter may cause pump, cylinder, or valve failure.

#### *Lubricating the Pump*

To extend pump life and improve performance, lubricate the beam pin, cross pin, and piston head and close release valve.

#### *Changing the Oil*

1. Drain all oil and refill with clean **ZINKO** oil every 12 months. If pump is used in dirty environments, change oil more often. Be sure to dispose of used oil properly.
2. Remove vent/fill cap or plug from reservoir.
3. Tilt pump to drain out old oil.
4. Replace the vent/fill cap or plug.
5. Regularly use roller bearing grease.

# Zinko Hydraulic Jack

## Model: ZHP-20 & ZHP-41

### Parts Breakdown

Part #	Description
920030-1	Pump Housing/Reservoir
920030-2	Screw
920030-3	Check Ball
920030-4	Set Screw
920030-5	O-Ring
920030-6	Backup Ring
920030-7	Pump Piston
920030-8	Snap Ring
920030-9	O-Ring
920030-10	Backup Ring
920030-11	Pump Piston
920030-12	Piston Ring
920030-13	Yoke Pin
920030-14	Retaining Ring
920030-15	Yoke
920030-16	Handle
920030-17	Handle Ring
920030-18	Oil Seal
920030-19	Couplers
920030-20	Release Valve
920030-21	Air Release Screw
920030-22	Check Ball
920030-23	Check Ball
920030-24	Spring
920030-25	Washer
920030-26	Valve Cover Screw
920030-27	Check Ball

### ZHP-20

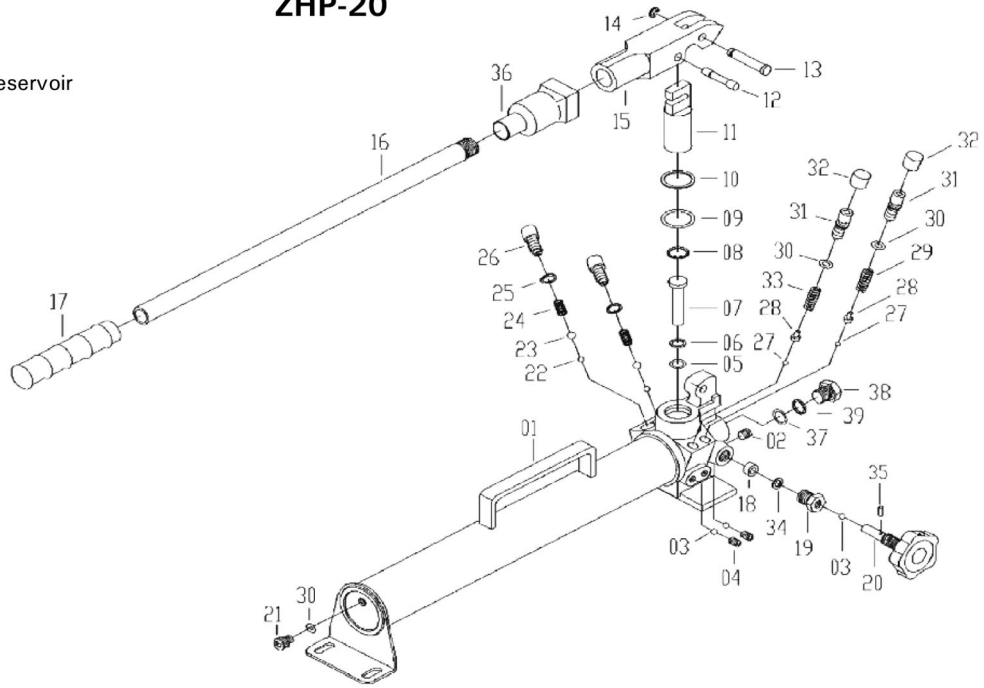

Part #	Description
920030-28	Spring End Cap
920030-29	Long Separator Spring
920030-30	O-Ring
920030-31	Overload Cover Screw
920030-32	Cap
920030-33	Short Separator Spring

Part #	Description
920030-34	Washer
920030-35	Pin
920030-36	Yoke Cover
920030-37	O-Ring
920030-38	Screw
920030-39	Backup Ring
920030-40	Seal Kit

### ZHP-41

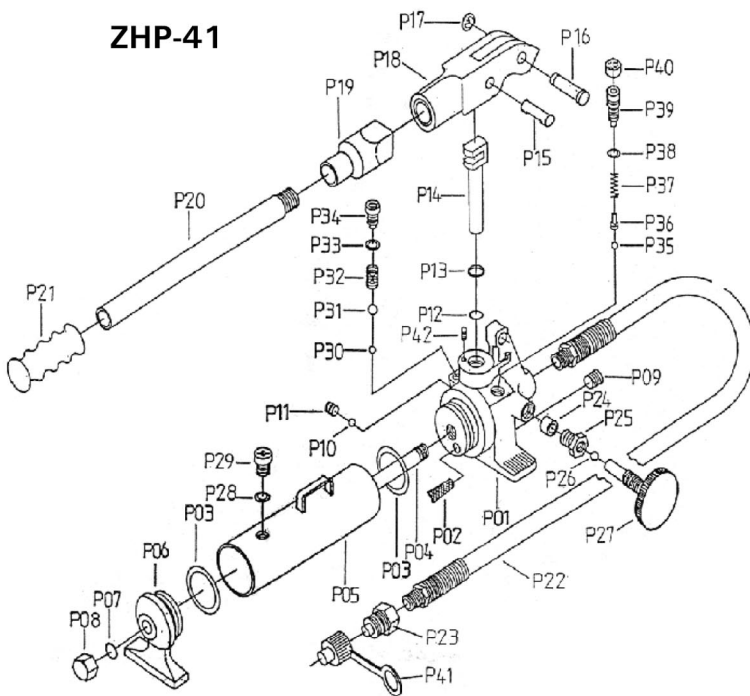

Part #	Description	Part #	Description
P01	Pump Housing	P26	Check Ball
P02	Oil Filter	P27	Release Valve
P03	O-Ring	P28	O-Ring
P04	Screw	P29	Screw
P05	Reservoir	P30	Check Ball
P06	Tail Base	P31	Check Ball
P07	O-Ring	P32	Spring
P08	Nipple	P33	Washer
P09	Screw	P34	Screw
P10	Check Ball	P35	Check Ball
P11	Set Screw	P36	Spring End Cap
P12	O-Ring	P37	Spring
P13	Back-Up Ring	P38	O-Ring
P14	Pump Piston	P39	Screw
P15	Piston Pin	P40	Plastic Cap
P16	Yoke Pin	P41	Dust Cap
P17	Retaining Ring	P42	Set Screw
P18	Yoke		
P19	Yoke Grip		
P20	Handle		
P21	Handle Grip		
P22	Screw		
P23	Couplers		
P24	Oil Seal		
P25	Couplers		

# Zinko Hydraulic Jack

## Model: ZHP-20 & ZHP-41

### Troubleshooting

PROBLEM	POSSIBLE CAUSE	SOLUTION
Cylinder does not advance, advances slowly, or advances in spurts.	Oil level in pump reservoir is low.	Add oil according to <i>Maintenance</i> section (page 2).
	Release valve is open.	Close the release valve.
	Loose hydraulic coupler.	Check that all couplers are fully tightened.
	Load is too heavy.	Do not attempt to lift more than rated tonnage.
	Air trapped in system.	Remove air according to instructions on page 2.
	Cylinder plunger binding.	Check for damage to the cylinder. Have cylinder serviced by a qualified hydraulic technician.
Cylinder advances, but does not hold pressure.	Leaking connection.	Check that all connection are tight and leak free.
	Leaking seals.	Locate leak(s) and have equipment serviced by a qualified hydraulic technician.
	Internal leakage in pump.	Locate leak(s) and have equipment serviced by a qualified hydraulic technician.
Cylinder does not retract, retracts part way, or retracts more slowly than normal.	Release valve close.	Open release valve.
	Pump reservoir is overfilled	Drain oil level to full mark. See page instructions for adding oil.
	Loose hydraulic coupler.	Check that all couplers are fully tightened.
	Air trapped in system.	Remove air according to instructions on page 2.
	Hose I.D. too narrow.	Use larger diameter hydraulic hose.
	Cylinder retraction spring broken or other cylinder damage.	Have cylinder serviced by a qualified service technician.

If the above procedures do not correct the problem, contact your nearest **ZINKO** service facility. When submitting any jack or equipment to be repaired, be sure to state the nature of the problem and indicate whether an estimate of the repair cost is needed.



**ZINKO HYDRAULIC JACK**

PO Box 4903, Ontario, CA 91761

Toll Free: 1-800-579-8088

[www.zinkojack.com](http://www.zinkojack.com)

Phone: (909) 230-4100

Fax: (909) 230-4137